

# aralco

natural ventilation systems

2500EA Series Slotvent

### Position vent

### Slot sizes

slot height H	position X below centerline	position Y above centerline	slot width R
13 mm*	X= 3 mm	Y= 2 mm	192 mm (+0 / -1)
14 mm*	X= 2 mm	Y= 1 mm	
15 mm*	X= 1 mm	Y= 1 mm	
16 mm*	X= centerline	Y= centerline	

\*tolerances slot height (-0 /+0.5)

Ensure **Canopy & Vent** are correctly positioned according to the instructions, to ensure the slot is not obstructed in any way that will impede air flow. If there are any questions regarding the fitting of this vent, please contact your local distributor.

- ① mill the routing as described
- ② open the plastic flaps, mount the vent in closed position
- ③ open the plastic flaps and mount the canopy
- ④ drill pilot hole and mount with included screws
- ⑤ close all 4 plastic flaps
- ⑥ ready to use: open the vent!

Position Vent

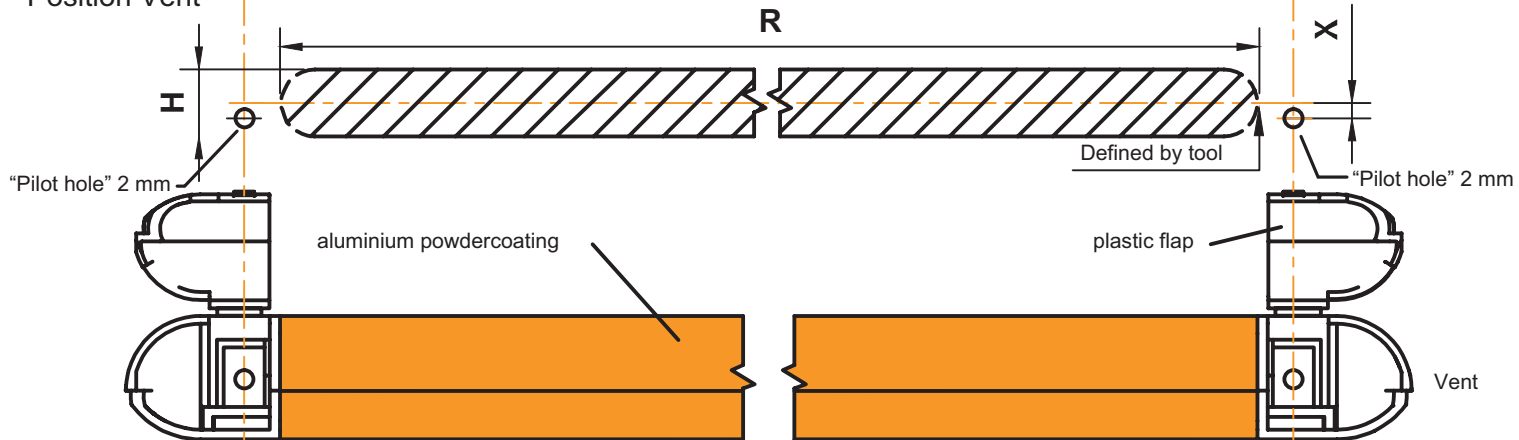

Position Canopy

